

**1-Wide or 3-Wide Welded Base
for Lockers without Legs**

RETAIN INSTRUCTIONS FOR FUTURE REFERENCE



GENERAL SAFETY INFORMATION

Some parts may have sharp edges. CARE must be taken when handling various pieces to avoid injury. For safety, wear a pair of work gloves when assembling or performing any maintenance on units.

LIMITED WARRANTY

Tennsco warrants goods purchased hereunder to be free of defects in materials and workmanship for a period of one (1) year from the date of shipment, hereunder. This warranty shall not apply in the event goods are damaged as a result of misuse, abuse, neglect, accident, improper application, modification or repair by persons not authorized by Seller, where goods are damaged during shipment, or where the date stamps on the goods have been defaced, modified or removed. UNLESS CONSIDERED UNENFORCEABLE OR UNLAWFUL UNDER APPLICABLE LAW:

- a. ALL IMPLIED WARRANTIES, INCLUDING BUT NOT LIMITED TO WARRANTIES OR MERCHANTABILITY AND FITNESS FOR A PARTICULAR PURPOSE ARE HEREBY EXCLUDED:
- b. BUYERS REMEDY, IF ANY, FOR ANY DEFECTIVE GOODS SHALL BE LIMITED TO A REFUND BY SELLER OR REPLACEMENT OF THE GOODS AT SELLER'S OPTION, AND SHALL IN NO EVENT INCLUDE DAMAGES OF ANY KIND, WHETHER INCIDENTAL, CONSEQUENTIAL OR OTHERWISE.

NO GOODS ACCEPTED FOR RETURN WITHOUT PRIOR APPROVAL. Seller shall have the right to inspect any goods claimed to be defective at Buyers place of business or require Buyer to return the goods to Seller for inspection on Seller's premises. Transportation charges covering returned goods will be borne by Seller only if such goods are proven to be defective, are covered by this warranty and are returned within the warranty period stated above.



PROUDLY MADE IN THE U.S.A.

Tennsco LLC., Dickson, TN 37056-1888 • (866) 446-8686

ATTACHMENT OF 1-WIDE WELDED LOCKER BASE

Two people required for assembly. Approximate assembly time: 5-10 minutes.

When Anchoring a 1-Wide Unit to the Floor:

- 1.** Securely mount the locker base to the floor. (Please use your local codes when mounting your unit. Codes may vary due to location.)

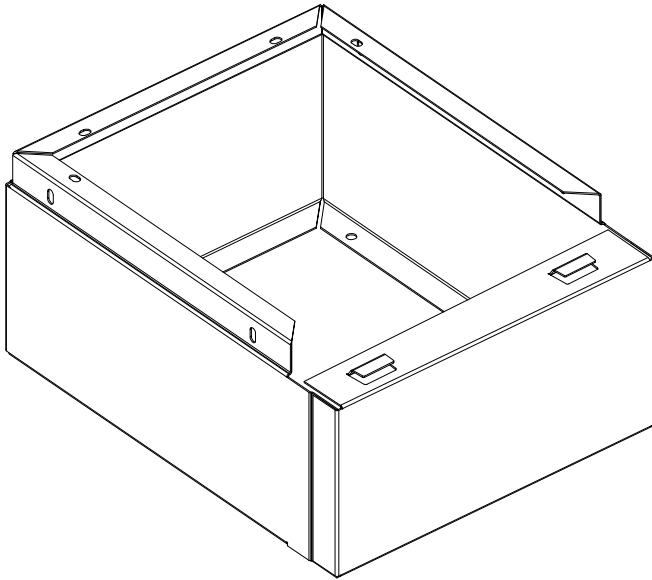

- 2.** With help from an associate, lift the unit at an angle and lock the front part of the unit in to the flanges of the base.

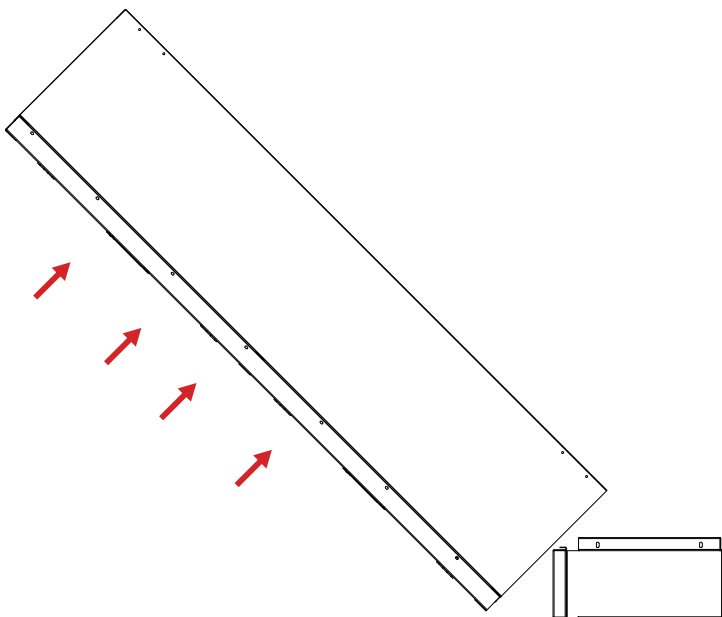

- 3.** In order to lock in the flanges, allow the front part of the unit to slip underneath the flanges on the base. Make sure that the unit is lined up with the base, with no excess sides hanging over the base.

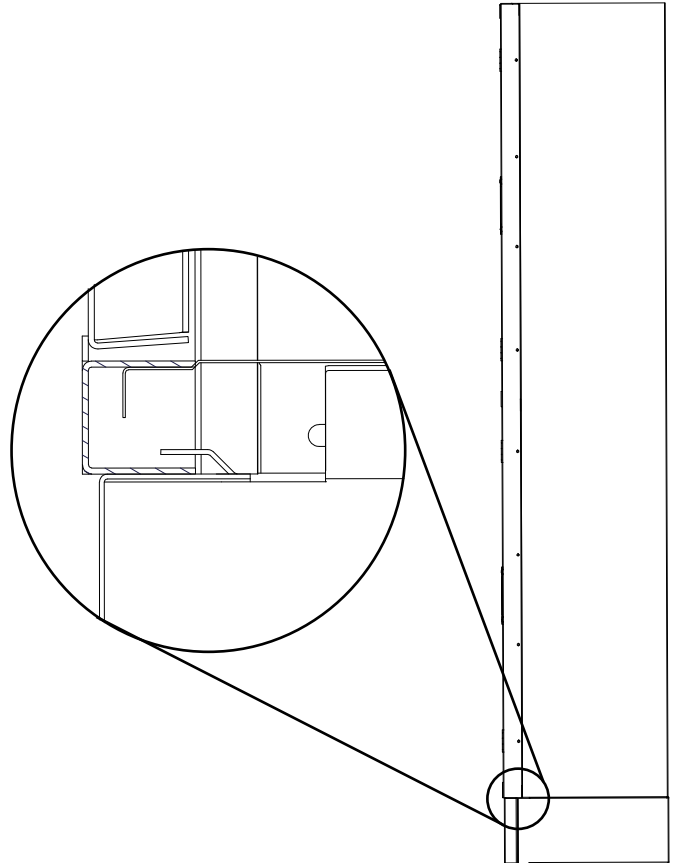

- 4.** Bolt two tech screws through the bottom shelf of the locker.

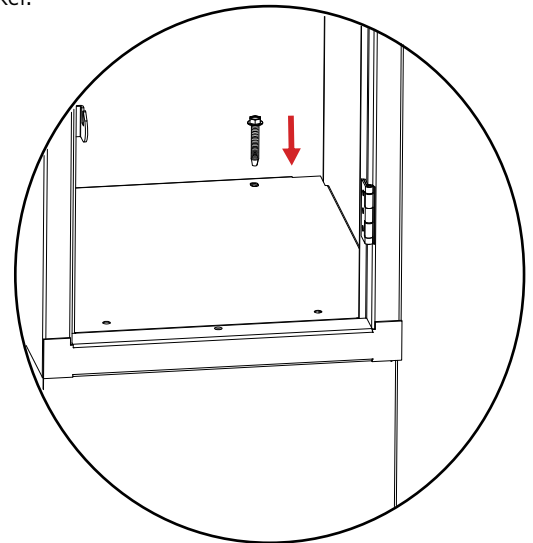

When Anchoring a 1-Wide Unit to the Wall or Another Locker:

1. Lay the locker on it's side. Use a tarp or cloth as a surface to ensure that the unit is not scratched.

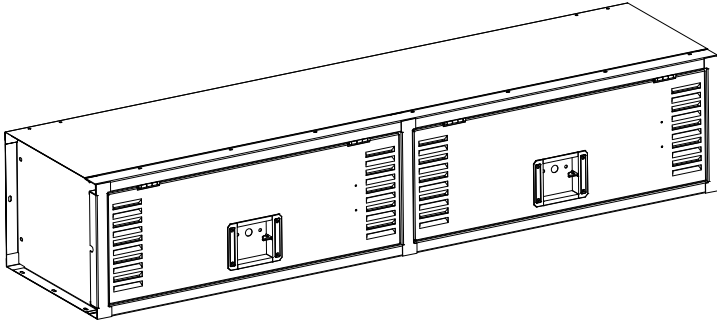

2. Attach the base by sliding the base over the top of the flanges on the bottom part of the unit to lock it into place.

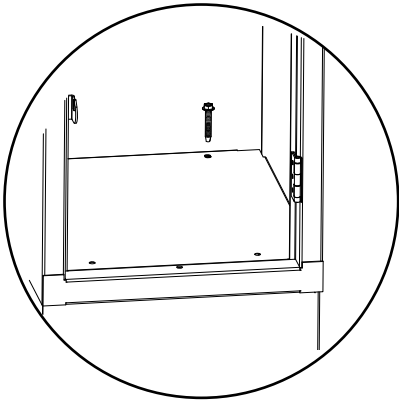
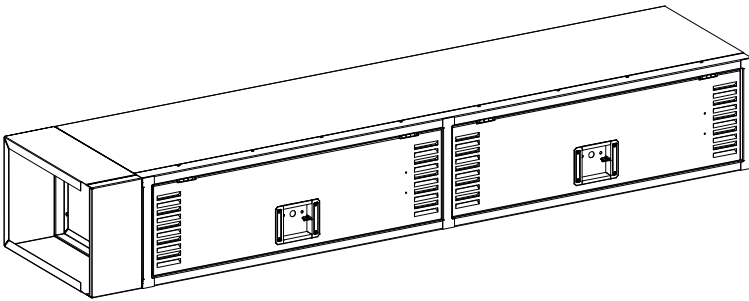

3. Bolt two tech screws through the bottom shelf of the locker.

4. With help from an associate, lift the locker to the initial upright position. Finish by securing the locker to the wall or to the next locker.

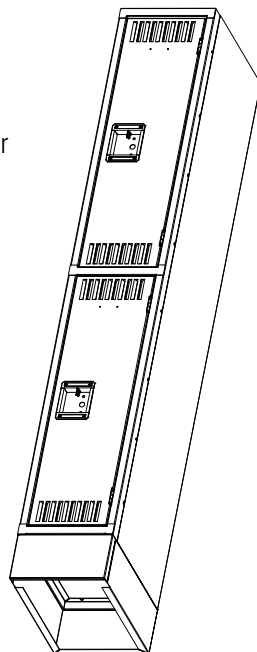

When Anchoring a 3-Wide Unit to the Floor:

1. Securely mount the locker base to the floor. (Please use your local codes when mounting your unit. Codes may vary due to location.)

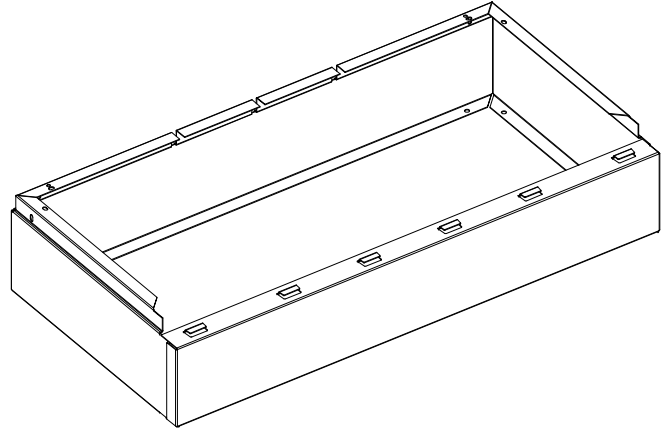

2. With help from an associate, lift the unit at an angle and lock the front part of the unit in to the flanges of the base.

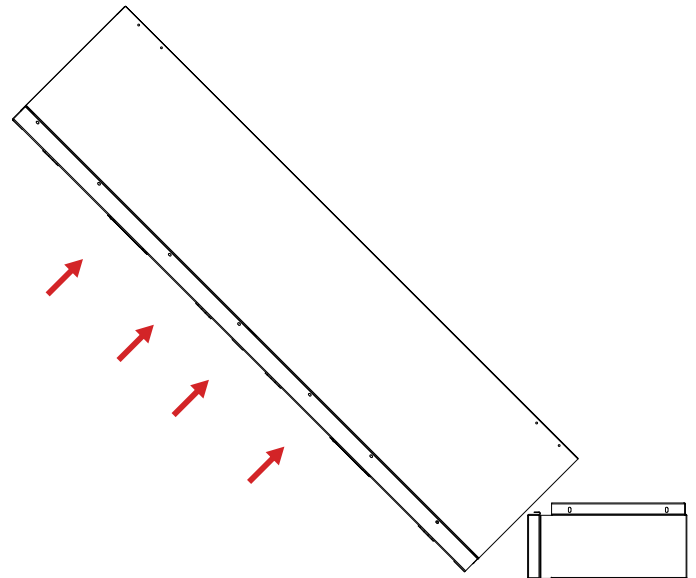

3. In order to lock in the flanges, allow the front part of the unit to slip underneath the flanges on the base. Make sure that the unit is lined up with the base, with no excess sides hanging over the base.

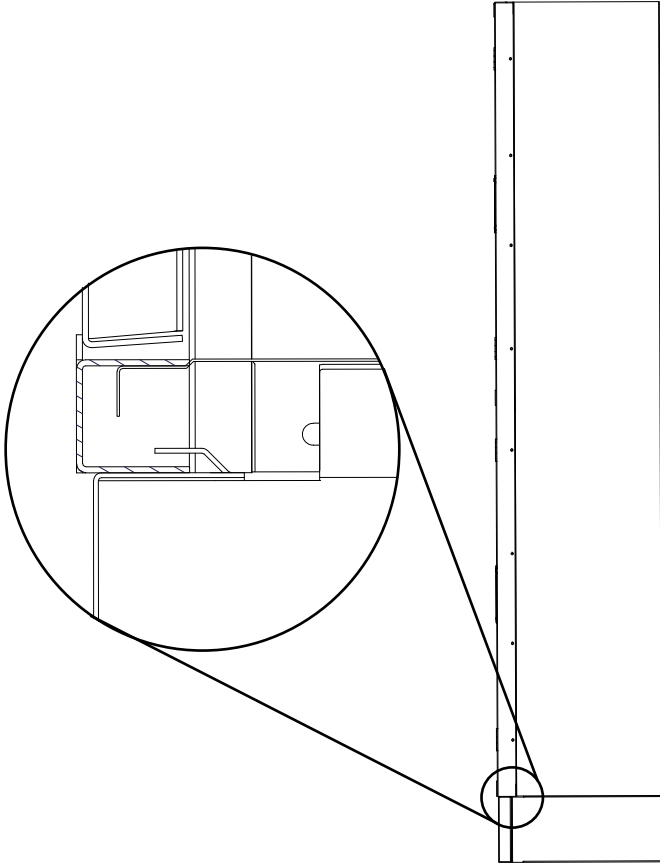

4. Bolt two tech screws through the bottom shelf of the locker.

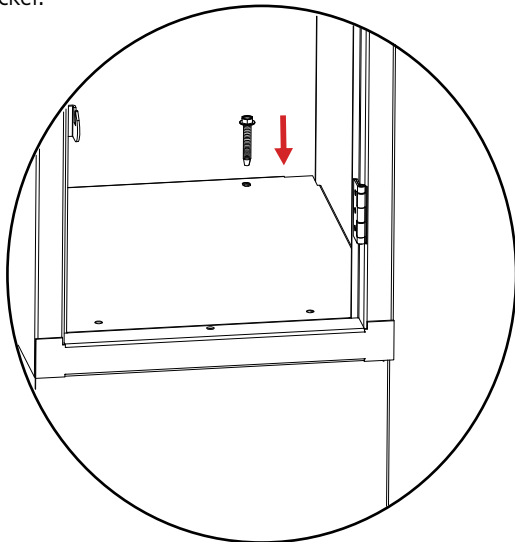

When Anchoring a 3-Wide Unit to the Wall or Another Locker:

1. Lay the locker on it's side. Use a tarp or cloth as a surface to ensure that the unit is not scratched.

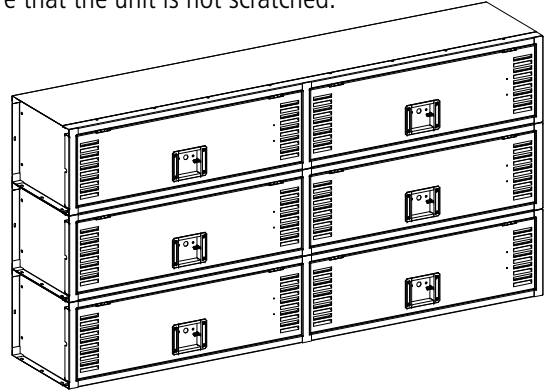

2. Attach the base by sliding the base over the top of the flanges on the bottom part of the unit to lock it into place.

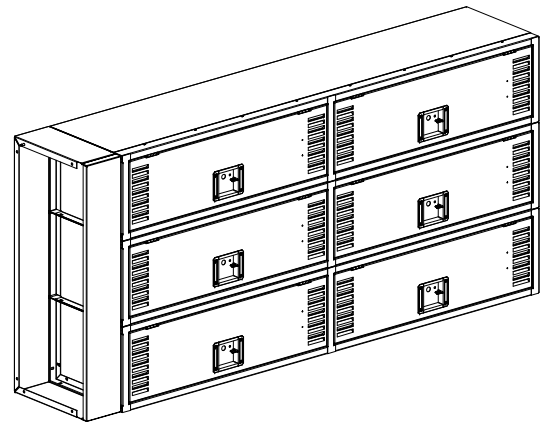

3. Bolt two tech screws through the bottom shelf of the locker.

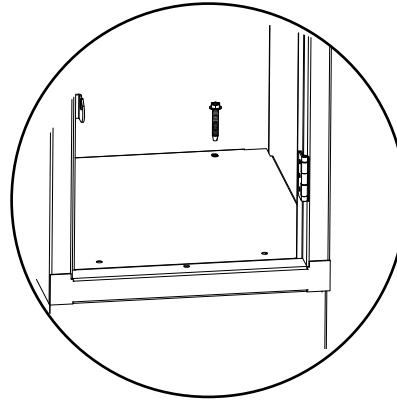

4. With help from an associate, lift the locker to the initial upright position. Finish by securing the locker to the wall or to the next locker.

